

# Weighing unit PK 1000

## Accessories for load cell K350 och K1000

Weighing unit type PK is used in S-E-G weighing systems for weighing small hoppers or platforms.

The weighing unit consists of two vertical members, interconnected by two accurately matched parallel flat springs.

Disturbing forces and torques acting on the load carrier will be taken up by the weighing unit without acting on the load cell.

The mounting holes have the same position on both sides of the unit. To reduce the influence from rough

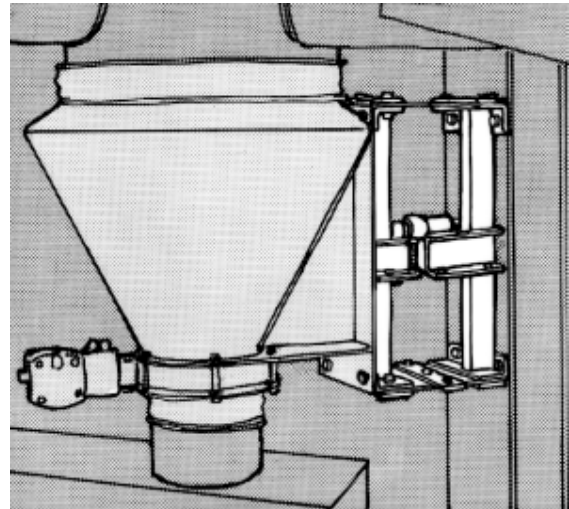

## Designations and specifications

Designation: PK-100 Maximum load: 1000 kg.

The centre of gravity of the load must fall within a circle with a max. radius of 500mm around the line of symmetry of the mounting surface. Refer to figure below.

Load cell K350 or K1000 depending on the actual gross weight. (To be ordered separately)

Coating: Blue enamel on rust resistant primer.

## Dimensions and weight

