

# Puls tacho F & drive

## Pulse tachometer type F

A belt weigher contains two measuring devices, a load transducer for determining the load on the belt and a tachometer for measuring the belt speed. Their signals are transmitted to a console, where they are converted to signals, corresponding to the material weight and flow.

The pulse tachometer type F is arranged to rotate proportionally to the belt speed. This can be achieved by coupling the tachometer shaft to the pulley of the conveyer or to an extra journal on the motor. Alternatively the tachometer may also be equipped with a measuring wheel, which is brought into contact with the return part of the belt. For this purpose a special driving device is available.

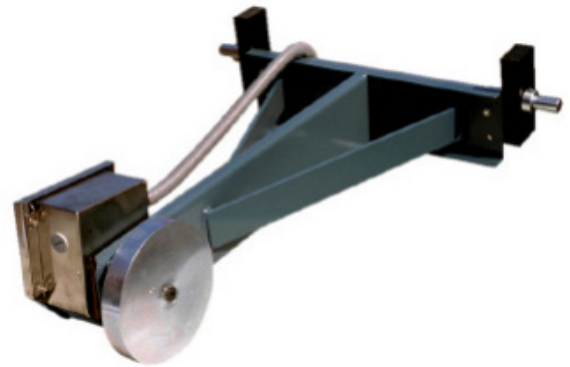

**Pulse tachometer type F with mounting accessories.** The pulse tachometer type F consists of a hole disc supported in a stable bearing, the disc openings sensed by an optical circuit. The tacho has a two-wire connection to the console. The pulse frequency at nominal speed is kept between 0,5-200 Hz selecting a disc with a suitable number of holes. The measuring device is enclosed in a box, from which the driving shaft protrudes. The housing is stainless steel AISI 304 with protection class IP 65 as standard. Optional version with all details (bearings etc.) in stainless steel available.

A special **mounting bracket type BD** is available, to provide a foot mounting. For direct drive a **coupling type JC** can be supplied, one side of which fits the tachometer shaft and the other side can be enlarged for a shaft of max. 30 mm diameter. Standard version with blue coating, optional epoxycoated or stainless versions available.

**Tachometer driving device type CF** This driving device gives the pulse tachometer with its measuring wheel. A definite contact pressure against the conveyer belt and must be mounted so that the wheel contacts the upper side of the return strand of the belt. It consists of a lever, running longitudinally to the belt and supported on a transverse shaft resting on two bearings. The bearings are fixed to the conveyer frame. The lever of the driving device is reversible, so that the tachometer box can be turned to the side, whichever is the best from a service point of view. Standard version with blue coating, optional epoxycoated or stainless versions available.

# Designation and specifications

## Pulse tachometer type F

When driving from tail pulley of conveyer or with drive CF.

Frequency 0,5-200 HZ

Designation: F-25 or F-25-SS for stainless version.

When driving directly from conveyer motor shaft. Max. 3600 rpm.

Designation: F-2. Pulse discs available: 1,2,4,8,16,25 and 40 holes.

C2-13: 2-conductor cable set (3 metres) in protective sleeving with glands.

## Electrical connection

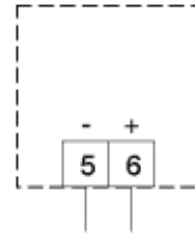

## Driving device type CF

When driving against the belt. To be used at nominal belt speeds in the range 0,01-4 m/s

Mounting bracket

Coupling

Designation **BD-XX**

Designation **JC-, JCS-xx**

## Version

-SS	STAINLESS STEEL VERSION SIS2333
-EP	EPOXYCOTED VERSION
-STD	STANDARD INDUSTRIAL ENAMEL

# Dimensions and weight

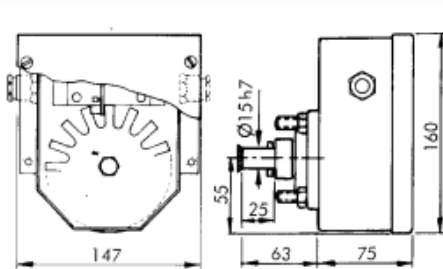

Weight: 2.3 kg

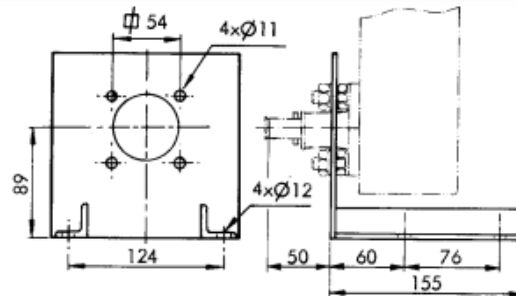

Weight: 1 kg

## DRIVING DEVICE CF

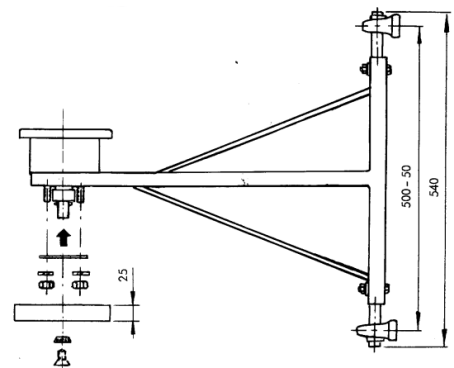
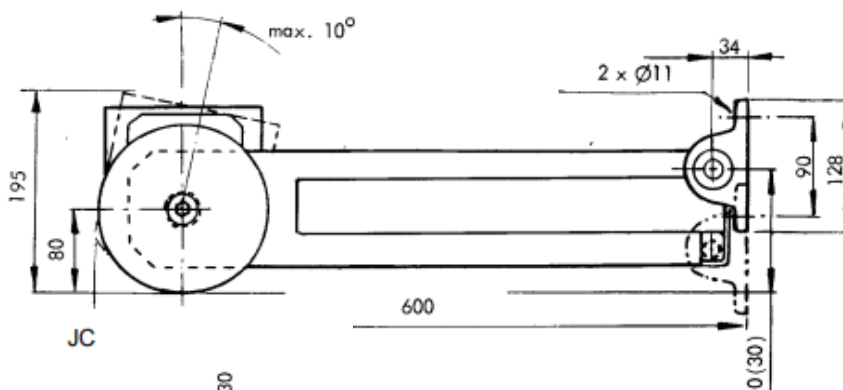

Weight: 14 kg

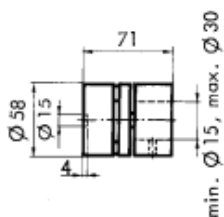

Weight: 1.1 kg